

DIECI



HERCULES

100.10 | 130.10 | 190.10 | 210.10 | 230.10



dieci.com

PERFORMANCE

Vehicle model	HERCULES 100.10	HERCULES 130.10	Hercules 190.10	Hercules 210.10	Hercules 230.10
Maximum capacity	10000 kg (22046 lb)	13000 kg (28660 lb)	19000 kg (41888 lb)	21000 kg (46297 lb)	23000 kg (50706 lb)
Maximum lifting height	9.5 m (31.2 ft)	9.5 m (31.2 ft)	10.2 m (33.5 ft)	10.2 m (33.5 ft)	10.15 m (33.3 ft)
Maximum horizontal extension	5.1 m (16.7 ft)	5.1 m (16.7 ft)	5.15 m (16.9 ft)	5.15 m (16.9 ft)	5.11 m (16.8 ft)
Fork swiveling angle	144°	144°	120°	120°	113°
Pull-out force	9700 daN (21806 lbf)	9700 daN (21806 lbf)	16200 daN (36419 lbf)	18900 daN (42489 lbf)	18900 daN (42489 lbf)
Towing force	11000 daN (24729 lbf)	11000 daN (24729 lbf)	19500 daN (43838 lbf)	19500 daN (43838 lbf)	19500 daN (43838 lbf)
Unladen weight	16000 kg (35274 lb)	18000 kg (39683 lb)	24500 kg (54013 lb)	27500 kg (60627 lb)	29000 kg (63934 lb)
Maximum climb angle	36 %	36 %	36.5 %	36.5 %	35 %
Max speed (referred to wheels with maximum permitted diameter)	34 km/h (21.1 mph)	34 km/h (21.1 mph)	23 km/h (14.3 mph)	23 km/h (14.3 mph)	22 km/h (13.7 mph)

BOOM

Vehicle model	HERCULES 100.10	HERCULES 130.10	Hercules 190.10	Hercules 210.10	Hercules 230.10
Getting off the basket	13.2 s	13 s	20.5 s	23.5 s	24.1 s
Lifting	16.5 s	20 s	20 s	25.2 s	28.6 s
Extension	13.2 s	13 s	20.1 s	20.1 s	20.1 s
Retraction	8.3 s	15 s	9.8 s	9.8 s	9.8 s
Forward swiveling	5.3 s	6.5 s	5.6 s	8.1 s	15.3 s
Reverse swiveling	4 s	5 s	4.3 s	5.3 s	10.5 s

ENGINE

Vehicle model	HERCULES 100.10	HERCULES 130.10	Hercules 190.10	Hercules 210.10	Hercules 230.10
Brand	FPT	FPT	FPT	FPT	FPT
Nominal power	125 kW (168 HP)	125 kW (168 HP)	125 kW (168 HP)	125 kW (168 HP)	125 kW (168 HP)
@rpm	2200 rpm	2200 rpm	2200 rpm	2200 rpm	2200 rpm
Peak power	128 kW (172 HP)	128 kW (172 HP)	128 kW (172 HP)	128 kW (172 HP)	128 kW (172 HP)
@rpm	1900 rpm	1900 rpm	1900 rpm	1900 rpm	1900 rpm
Operation	4-stroke	4-stroke	4-stroke	4-stroke	4-stroke
Injection	Electronic, Common Rail	Electronic, Common Rail	Electronic, Common Rail	Electronic, Common Rail	Electronic, Common Rail
Number and arrangement of cylinders	4, Vertical in line	4, Vertical in line	4, Vertical in line	4, Vertical in line	4, Vertical in line
Displacement	4485 cm ³ (274 in ³)	4485 cm ³ (274 in ³)	4485 cm ³ (274 in ³)	4485 cm ³ (274 in ³)	4485 cm ³ (274 in ³)
Consumption	212 g/kWh (348.74 lb/Hp h)	212 g/kWh (348.74 lb/Hp h)	212 g/kWh (348.74 lb/Hp h)	212 g/kWh (348.74 lb/Hp h)	212 g/kWh (348.74 lb/Hp h)
@rpm	2200 rpm	2200 rpm	2200 rpm	2200 rpm	2200 rpm
Emission standards	Stage V	Stage V	Stage V	Stage V	Stage V
Exhaust gas treatment	DOC+SCRoF (with AdBlue)	DOC+SCRoF (with AdBlue)	DOC+SCRoF (with AdBlue)	DOC+SCRoF (with AdBlue)	DOC+SCRoF (with AdBlue)
Cooling system	Liquid	Liquid	Liquid	Liquid	Liquid
Intake	16-valve turbocharger with aftercooler	16-valve turbocharger with aftercooler	16-valve turbocharger with aftercooler	16-valve turbocharger with aftercooler	16-valve turbocharger with aftercooler
Air filter	Air pre-heating and air pre-filtering with dust separator	Air pre-heating and air pre-filtering with dust separator	Air pre-heating and air pre-filtering with dust separator	Air pre-heating and air pre-filtering with dust separator	Air pre-heating and air pre-filtering with dust separator

TRANSMISSION

Vehicle model	HERCULES 100.10	HERCULES 130.10	Hercules 190.10	Hercules 210.10	Hercules 230.10
Transmission type	Hydrostatic with variable displacement pump	Hydrostatic with variable displacement pump	Hydrostatic with variable displacement pump	Hydrostatic with variable displacement pump	Hydrostatic with variable displacement pump
Hydraulic motor	Hydrostatic with continuous automatic adjustment	Hydrostatic with continuous automatic adjustment	Hydrostatic with continuous automatic adjustment	Hydrostatic with continuous automatic adjustment	Hydrostatic with continuous automatic adjustment
Reversal	Electro-Hydraulic	Electro-Hydraulic	Electro-Hydraulic	Electro-Hydraulic	Electro-Hydraulic
Inching	With electronic pedal for controlled forward movement	With electronic pedal for controlled forward movement	With electronic pedal for controlled forward movement	With electronic pedal for controlled forward movement	With electronic pedal for controlled forward movement
Gearbox	Servo-controlled 2-speed	Servo-controlled 2-speed	Servo-controlled 2-speed	Servo-controlled 2-speed	Servo-controlled 2-speed

DIFFERENTIAL AXLES

Vehicle model	HERCULES 100.10	HERCULES 130.10	Hercules 190.10	Hercules 210.10	Hercules 230.10
Type of axles	2 steering, with 4 epicycloidal reduction gears	2 steering, with 4 epicycloidal reduction gears	2 steering, with 4 epicycloidal reduction gears	2 steering, with 4 epicycloidal reduction gears	2 steering, with 4 epicycloidal reduction gears
Type of steering	4 wheels / transversal / 2 wheels	4 wheels / transversal / 2 wheels	4 wheels / transversal / 2 wheels	4 wheels / transversal / 2 wheels	4 wheels / transversal / 2 wheels
Front axle	With transverse leveling device (8° + 8°) with control in the cab and 45% self-locking differential	With transverse leveling device (8° + 8°) with control in the cab and 45% self-locking differential	With transverse leveling device (8° + 8°) with control in the cab	With transverse leveling device (8° + 8°) with control in the cab	With transverse leveling device (6° + 6°) with control in the cab
Rear axle	Swinging	Swinging	Swinging	Swinging	Swinging
Service braking	Oil bath with servo brake on front and rear axle with double hydraulic system	Oil bath with servo brake on front and rear axle with double hydraulic system	Oil bath with servo brake on front and rear axle with double hydraulic system	Oil bath with servo brake on front and rear axle with double hydraulic system	Oil bath with servo brake on front and rear axle with double hydraulic system
Parking braking	Negative actuation with electrical control	Negative actuation with electrical control	Negative actuation with electronic control	Negative actuation with electronic control	Negative actuation with electronic control

HYDRAULIC SYSTEM

Vehicle model	HERCULES 100.10	HERCULES 130.10	Hercules 190.10	Hercules 210.10	Hercules 230.10
Hydraulic pump type	"Load Sensing" variable flow pump for boom movements. Gear pump for power steering drive and for the cooling fan	"Load Sensing" variable flow pump for boom movements. Gear pump for power steering drive and for the cooling fan	"Load Sensing" variable flow pump for boom movements. And power steering. Gear pump for auxiliary services operation.	"Load Sensing" variable flow pump for boom movements. And power steering. Gear pump for auxiliary services operation.	"Load Sensing" variable flow pump for boom movements. And power steering. Gear pump for auxiliary services operation.
Hydraulic pump capacity	160 l/min (42.3 gal/min)	160 l/min (42.3 gal/min)	225 l/min (59.4 gal/min)	225 l/min (59.4 gal/min)	225 l/min (59.4 gal/min)
Max. operating pressure	31 MPa (4496 psi)	31 MPa (4496 psi)	35 MPa (5076 psi)	35 MPa (5076 psi)	35 MPa (5076 psi)
Distributor control	Proportional 4in1 Joystick	Proportional 4in1 Joystick	Proportional 4in1 Joystick	Proportional 4in1 Joystick	Proportional 4 in 1 Joystick with FNR
Distributor type	"Flow Sharing" servo controlled hydraulic	"Flow Sharing" servo controlled hydraulic	Hydraulic servo-controlled "Flow Sharing" with electronic proportional 4-in-1 joystick	Hydraulic servo-controlled "Flow Sharing" with electronic proportional 4-in-1 joystick	Hydraulic servo-controlled "Flow Sharing" with electronic proportional 4-in-1 joystick

FILLING

Vehicle model	HERCULES 100.10	HERCULES 130.10	Hercules 190.10	Hercules 210.10	Hercules 230.10
Hydraulic system (total)	246 l (64.99 gal)	298 l (78.72 gal)	330 l (87.18 gal)	347 l (91.67 gal)	360 l (95.10 gal)
Diesel tank	207 l (54.68 gal)	207 l (54.68 gal)	207 l (54.68 gal)	207 l (54.68 gal)	207 l (54.68 gal)
AdBlue tank	34 l (8.98 gal)	34 l (8.98 gal)	34 l (8.98 gal)	34 l (8.98 gal)	34 l (8.98 gal)

TYRES

Vehicle model	HERCULES 100.10	HERCULES 130.10	Hercules 190.10	Hercules 210.10	Hercules 230.10
Standard tires	17.5x25"	17.5x25"	16.00 - 25"	18.00 - 25"	18.00R25"

DIMENSIONS

Vehicle model	HERCULES 100.10	HERCULES 130.10	Hercules 190.10	Hercules 210.10	Hercules 230.10
A	490 mm (19.3 in)	490 mm (19.3 in)	530 mm (20.9 in)	530 mm (20.9 in)	470 mm (18.5 in)
B	1270 mm (50.0 in)	1270 mm (50.0 in)	1320 mm (52.0 in)	1320 mm (52.0 in)	1320 mm (52.0 in)
C	3300 mm (129.9 in)	3300 mm (129.9 in)	3850 mm (151.6 in)	3850 mm (151.6 in)	3850 mm (151.6 in)
D	1480 mm (58.3 in)	1480 mm (58.3 in)	1630 mm (64.2 in)	1630 mm (64.2 in)	1630 mm (64.2 in)
G	6050 mm (238.2 in)	6050 mm (238.2 in)	6800 mm (267.7 in)	6800 mm (267.7 in)	6800 mm (267.7 in)
H	2890 mm (113.8 in)	2890 mm (113.8 in)	2930 mm (115.4 in)	2930 mm (115.4 in)	2980 mm (117.3 in)
I	980 mm (38.6 in)	980 mm (38.6 in)	980 mm (38.6 in)	980 mm (38.6 in)	980 mm (38.6 in)
L	1975 mm (77.8 in)	1975 mm (77.8 in)	2015 mm (79.3 in)	2045 mm (80.5 in)	2180 mm (85.8 in)
M	2420 mm (95.3 in)	2420 mm (95.3 in)	2550 mm (100.4 in)	2550 mm (100.4 in)	2700 mm (106.3 in)
P	1070 mm (42.1 in)	1070 mm (42.1 in)	3530 mm (139.0 in)	3530 mm (139.0 in)	3530 mm (139.0 in)
Q	3950 mm (155.5 in)	3950 mm (155.5 in)	6500 mm (255.9 in)	6500 mm (255.9 in)	6530 mm (257.1 in)
R	4180 mm (164.6 in)	4180 mm (164.6 in)	6500 mm (255.9 in)	6750 mm (265.7 in)	6750 mm (265.7 in)
T	134 mm (5.3 in)	134 mm (5.3 in)	181 mm (7.1 in)	181 mm (7.1 in)	181 mm (7.1 in)

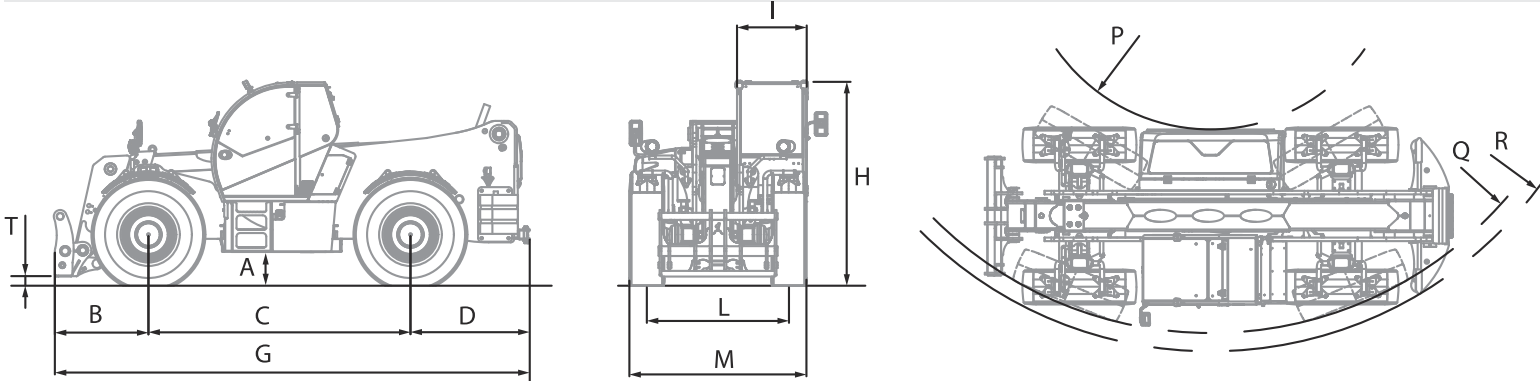

MAX 10,0 t

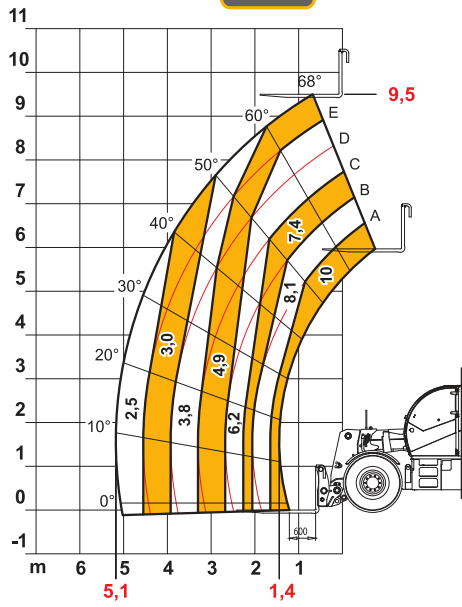

AXB1537



EN1459

100.10

MAX 13000 kg

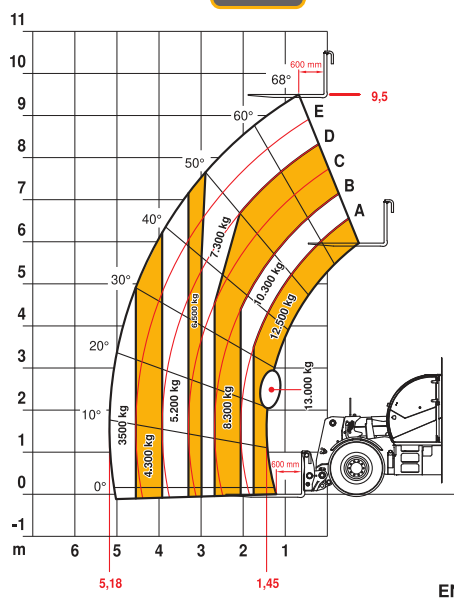

DOC10001354



EN1459 (B)

130.10

MAX 19,0 t

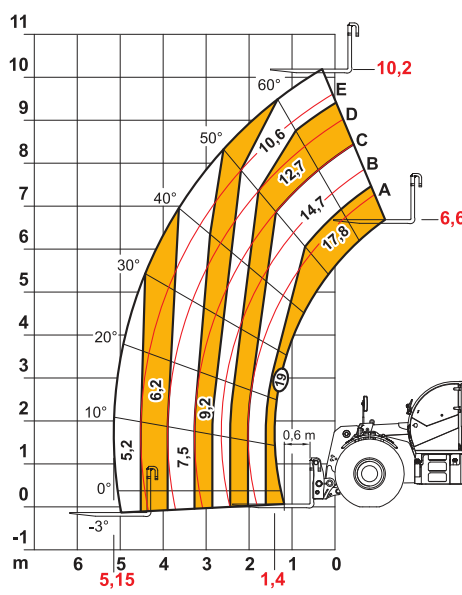

DOC10000197



EN1459

190.10

MAX 21,0 t

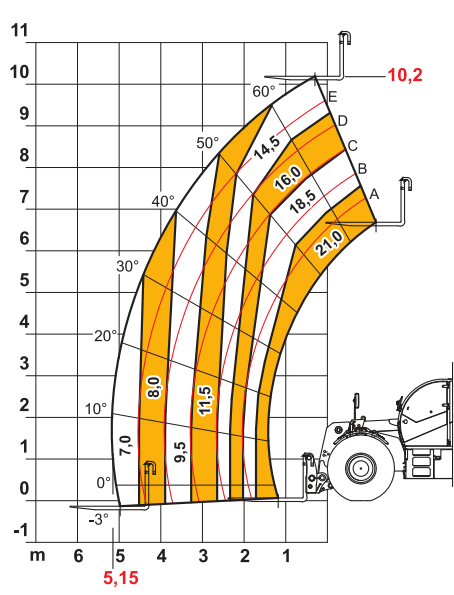

AXB1452



EN1459

210.10

MAX 23000 kg / 50706 lb

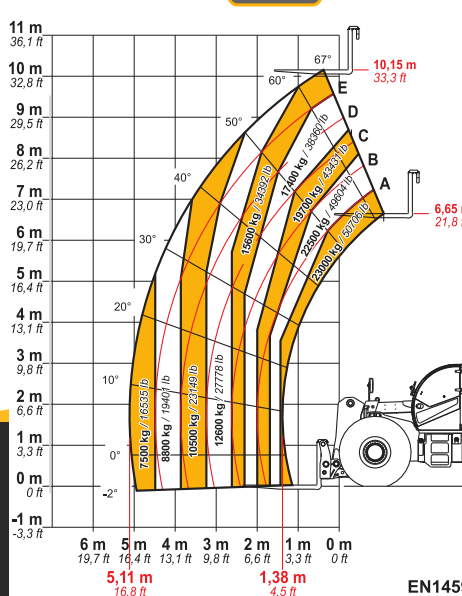

DOC10000810



EN1459 Annex-B

230.10