

DIECI



ZEUS

40.8 | 38.10 | 35.11 | 40.13



dieci.com

PERFORMANCE

Vehicle model	ZEUS 40.8 - GD	ZEUS 38.10 - GD	ZEUS 35.11 - GD	ZEUS 40.13 - GD
Maximum capacity	4000 kg (8818 lb)	3800 kg (8378 lb)	3500 kg (7716 lb)	4000 kg (8818 lb)
Maximum lifting height	7.6 m (24.9 ft)	9.6 m (31.5 ft)	10.6 m (34.8 ft)	12.5 m (41.0 ft)
Maximum horizontal extension	4.4 m (14.4 ft)	6.2 m (20.3 ft)	6.9 m (22.6 ft)	8.5 m (27.9 ft)
Fork swiveling angle	146°	146°	146°	146°
Pull-out force	8200 daN (18434 lbf)	8200 daN (18434 lbf)	8200 daN (18434 lbf)	8200 daN (18434 lbf)
Towing force	8300 daN (18659 lbf)	8300 daN (18659 lbf)	8300 daN (18659 lbf)	8300 daN (18659 lbf)
Unladen weight	8400 kg (18519 lb)	8700 kg (19180 lb)	8900 kg (19621 lb)	8900 kg (19621 lb)
Maximum climb angle	45 %	45 %	45 %	45 %
Max speed (referred to wheels with maximum permitted diameter)	30 km/h (18.6 mph)	30 km/h (18.6 mph)	30 km/h (18.6 mph)	30 km/h (18.6 mph)

BOOM

Vehicle model	ZEUS 40.8 - GD	ZEUS 38.10 - GD	ZEUS 35.11 - GD	ZEUS 40.13 - GD
Getting off the basket	7.1 s	8.2 s	8.2 s	12.5 s
Lifting	9.1 s	10.3 s	10.3 s	13.5 s
Extension	6.8 s	6.7 s	7.5 s	11.6 s
Retraction	5.1 s	4 s	4.5 s	8.8 s
Forward swiveling	4.6 s	4.6 s	4.6 s	4.6 s
Reverse swiveling	2.6 s	2.6 s	2.6 s	2.6 s

ENGINE

Vehicle model	ZEUS 40.8 - GD	ZEUS 38.10 - GD	ZEUS 35.11 - GD	ZEUS 40.13 - GD
Brand	Kubota	Kubota	Kubota	Kubota
Nominal power	54.6 kW (73 HP)	54.6 kW (73 HP)	54.6 kW (73 HP)	54.6 kW (73 HP)
@rpm	2600 rpm	2600 rpm	2600 rpm	2600 rpm
@rpm	2600 rpm	2600 rpm	2600 rpm	2600 rpm
Operation	4-stroke	4-stroke	4-stroke	4-stroke
Injection	Electronic, Common Rail	Electronic, Common Rail	Electronic, Common Rail	Electronic, Common Rail
Number and arrangement of cylinders	4, Vertical in line	4, Vertical in line	4, Vertical in line	4, Vertical in line
Displacement	3331 cm ³ (203 in ³)	3331 cm ³ (203 in ³)	3331 cm ³ (203 in ³)	3331 cm ³ (203 in ³)
Consumption	231 g/kWh (380.00 lb/Hp h)	231 g/kWh (380.00 lb/Hp h)	231 g/kWh (380.00 lb/Hp h)	231 g/kWh (380.00 lb/Hp h)
@rpm	2600 rpm	2600 rpm	2600 rpm	2600 rpm
Emission standards	Stage V/Tier 4f	Stage V/Tier 4f	Stage V/Tier 4f	Stage V/Tier 4f
Exhaust gas treatment	DOC+DPF	DOC+DPF	DOC+DPF	DOC+DPF
Cooling system	Liquid	Liquid	Liquid	Liquid
Intake	Turbocharger after-cooler	Turbocharger after-cooler	Turbocharger after-cooler	Turbocharger after-cooler
Air filter	Air pre-heating and air pre-filtering with dust separator	Air pre-heating and air pre-filtering with dust separator	Air pre-heating and air pre-filtering with dust separator	Air pre-heating and air pre-filtering with dust separator

TRANSMISSION

Vehicle model	ZEUS 40.8 - GD	ZEUS 38.10 - GD	ZEUS 35.11 - GD	ZEUS 40.13 - GD
Transmission type	Hydrostatic with variable displacement pump	Hydrostatic with variable displacement pump	Hydrostatic with variable displacement pump	Hydrostatic with variable displacement pump
Hydraulic motor	Hydrostatic with continuous automatic adjustment	Hydrostatic with continuous automatic adjustment	Hydrostatic with continuous automatic adjustment	Hydrostatic with continuous automatic adjustment
Reversal	With electronic control operated with vehicle in motion	With electronic control operated with vehicle in motion	With electronic control operated with vehicle in motion	With electronic control operated with vehicle in motion
Inching	With electronic pedal for controlled forward movement	With electronic pedal for controlled forward movement	With electronic pedal for controlled forward movement	With electronic pedal for controlled forward movement
Gearbox	Servo-controlled 2-speed	Servo-controlled 2-speed	Servo-controlled 2-speed	Servo-controlled 2-speed

DIFFERENTIAL AXLES

Vehicle model	ZEUS 40.8 - GD	ZEUS 38.10 - GD	ZEUS 35.11 - GD	ZEUS 40.13 - GD
Type of axles	2 steering, with 4 epicycloidal reduction gears	2 steering, with 4 epicycloidal reduction gears	2 steering, with 4 epicycloidal reduction gears	2 steering, with 4 epicycloidal reduction gears
Type of steering	4 wheels / transversal / 2 wheels	4 wheels / transversal / 2 wheels	4 wheels / transversal / 2 wheels	4 wheels / transversal / 2 wheels
Front axle	Rigid (OPT leveling.)	Rigid (OPT leveling.)	Rigid (OPT leveling.)	With transverse leveling device with control in the cab
Rear axle	Swinging	Swinging	Swinging	Swinging
Service braking	Oil bath with servo brake on front axle with double hydraulic system	Oil bath with servo brake on front axle with double hydraulic system	Oil bath with servo brake on front axle with double hydraulic system	Oil bath with servo brake on front axle with double hydraulic system
Parking braking	Negative actuation with electronic control	Negative actuation with electronic control	Negative actuation with electronic control	Negative actuation with electronic control

HYDRAULIC SYSTEM

Vehicle model	ZEUS 40.8 - GD	ZEUS 38.10 - GD	ZEUS 35.11 - GD	ZEUS 40.13 - GD
Hydraulic pump type	No. 1 LS piston pump for power-steering and boom movements. No. 1 gear pump for and Fan Drive.	No. 1 LS piston pump for power-steering and boom movements. No. 1 gear pump for and Fan Drive.	No. 1 LS piston pump for power-steering and boom movements. No. 1 gear pump for and Fan Drive.	No. 1 LS piston pump for power-steering and boom movements. No. 1 gear pump for and Fan Drive.
Hydraulic pump capacity	127 l/min (33.5 gal/min)	127 l/min (33.5 gal/min)	127 l/min (33.5 gal/min)	127 l/min (33.5 gal/min)
Max. operating pressure	26 MPa (3771 psi)	26 MPa (3771 psi)	26 MPa (3771 psi)	26 MPa (3771 psi)
Distributor control	Proportional 4 in 1 Joystick with FNR	Proportional 4 in 1 Joystick with FNR	Proportional 4 in 1 Joystick with FNR	Proportional 4 in 1 Joystick with FNR
Distributor type	Hydraulic control distributor-single joystick with proportional and simultaneous controls (Flow Sharing) with integrated priority.	Hydraulic control distributor-single joystick with proportional and simultaneous controls (Flow Sharing)	Hydraulic control distributor-single joystick with proportional and simultaneous controls (Flow Sharing)	Hydraulic control distributor-single joystick with proportional and simultaneous controls (Flow Sharing)
Outriggers	-	No	Two with proportional control and independent from the cab	Two with proportional control and independent from the cab

FILLING

Vehicle model	ZEUS 40.8 - GD	ZEUS 38.10 - GD	ZEUS 35.11 - GD	ZEUS 40.13 - GD
Hydraulic system (total)	170 l (44.91 gal)	170 l (44.91 gal)	170 l (44.91 gal)	170 l (44.91 gal)
Diesel tank	175 l (46.23 gal)	175 l (46.23 gal)	175 l (46.23 gal)	175 l (46.23 gal)

TYRES

Vehicle model	ZEUS 40.8 - GD	ZEUS 38.10 - GD	ZEUS 35.11 - GD	ZEUS 40.13 - GD
Standard tires	405/70-24" (16/70-24)"	405/70-24" (16/70-24)"	405/70-24" (16/70-24)"	405/70-24" (16/70-24)"

DIMENSIONS

Vehicle model	ZEUS 40.8 - GD	ZEUS 38.10 - GD	ZEUS 35.11 - GD	ZEUS 40.13 - GD
A	360 mm (14.2 in)	360 mm (14.2 in)	360 mm (14.2 in)	360 mm (14.2 in)
B	1748 mm (68.8 in)	1307 mm (51.5 in)	1601 mm (63.0 in)	1950 mm (76.8 in)
C	2750 mm (108.3 in)	2750 mm (108.3 in)	2750 mm (108.3 in)	2750 mm (108.3 in)
D	937 mm (36.9 in)	937 mm (36.9 in)	920 mm (36.2 in)	1270 mm (50.0 in)
E1	2860 mm (112.6 in)	2860 mm (112.6 in)	2860 mm (112.6 in)	2860 mm (112.6 in)
F	4276 mm (168.3 in)	4276 mm (168.3 in)	4250 mm (167.3 in)	4600 mm (181.1 in)
G	5227 mm (205.8 in)	5050 mm (198.8 in)	5350 mm (210.6 in)	6050 mm (238.2 in)
H	2410 mm (94.9 in)	2410 mm (94.9 in)	2410 mm (94.9 in)	2410 mm (94.9 in)
I	960 mm (37.8 in)	960 mm (37.8 in)	960 mm (37.8 in)	960 mm (37.8 in)
L	1870 mm (73.6 in)	1870 mm (73.6 in)	1870 mm (73.6 in)	1870 mm (73.6 in)
L1	5572 mm (219.4 in)	5159 mm (203.1 in)	5420 mm (213.4 in)	6100 mm (240.2 in)
K01	31°	31°	32°	23°
K03	9°	9°	10°	10°
K06	150°	150°	150°	150°
K07	16°	16°	16°	18°
K08	131°	131°	131°	140°
M	2290 mm (90.2 in)	2290 mm (90.2 in)	2290 mm (90.2 in)	2290 mm (90.2 in)
M1	1885 mm (74.2 in)	1472 mm (58.0 in)	1750 mm (68.9 in)	2080 mm (81.9 in)
N1	1755 mm (69.1 in)	1755 mm (69.1 in)	1755 mm (69.1 in)	1755 mm (69.1 in)
O1	6635 mm (261.2 in)	6195 mm (243.9 in)	1200 mm (47.2 in)	7170 mm (282.3 in)
P	1030 mm (40.6 in)	1030 mm (40.6 in)	1030 mm (40.6 in)	1030 mm (40.6 in)
P1	45 mm (1.8 in)	45 mm (1.8 in)	45 mm (1.8 in)	45 mm (1.8 in)
Q	3665 mm (144.3 in)	3665 mm (144.3 in)	3665 mm (144.3 in)	3665 mm (144.3 in)
Q1	1200 mm (47.2 in)	1200 mm (47.2 in)	1200 mm (47.2 in)	1200 mm (47.2 in)
R1	1100 mm (43.3 in)	1100 mm (43.3 in)	1100 mm (43.3 in)	1100 mm (43.3 in)
S1	120 mm (4.7 in)	120 mm (4.7 in)	120 mm (4.7 in)	120 mm (4.7 in)
T1	5127 mm (201.9 in)	4759 mm (187.4 in)	4940 mm (194.5 in)	5245 mm (206.5 in)
U1	4097 mm (161.3 in)	3729 mm (146.8 in)	3940 mm (155.1 in)	4245 mm (167.1 in)
V1	9463 mm (372.6 in)	8655 mm (340.7 in)	9120 mm (359.1 in)	9770 mm (384.6 in)

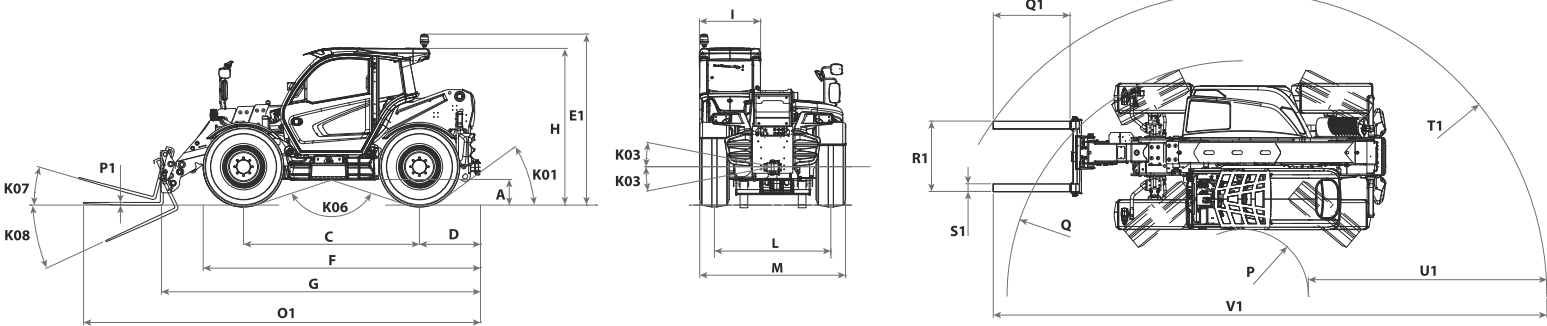

MAX
4000 kg



DOC10001724

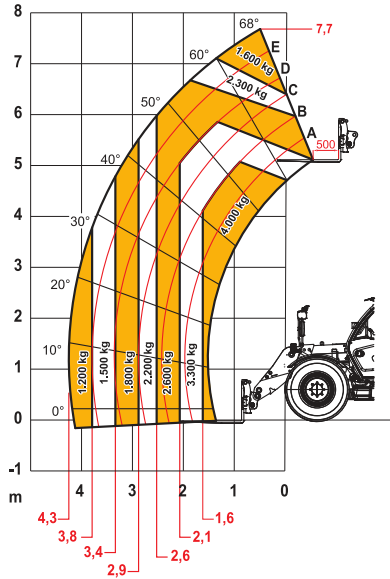

EN1459

40.8

MAX
3800 kg / 8378 lb



DOC10000837

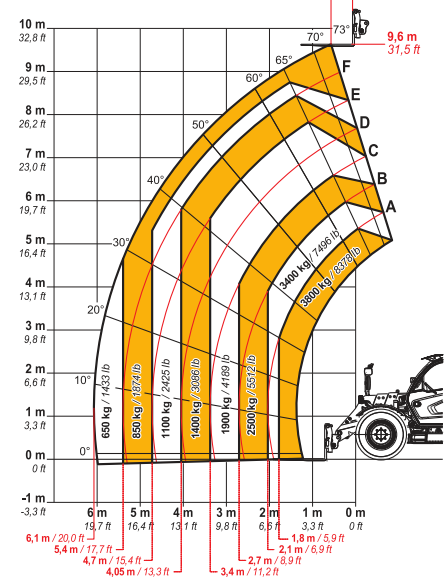

EN1459

38.10

MAX
3500 kg / 7716 lb



DOC10001195

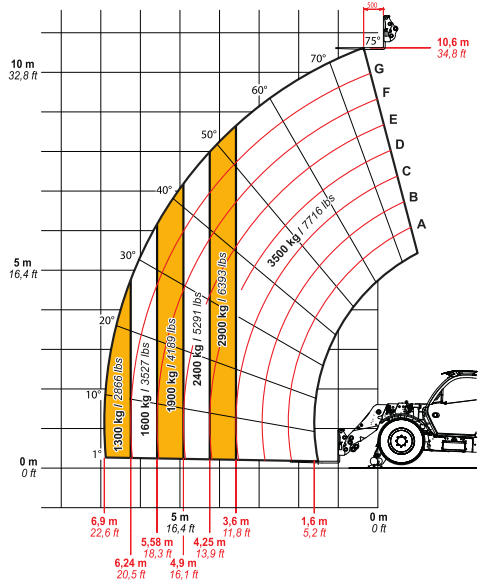

EN1459

35.11

MAX
4000 kg / 8818 lb



DOC10001197

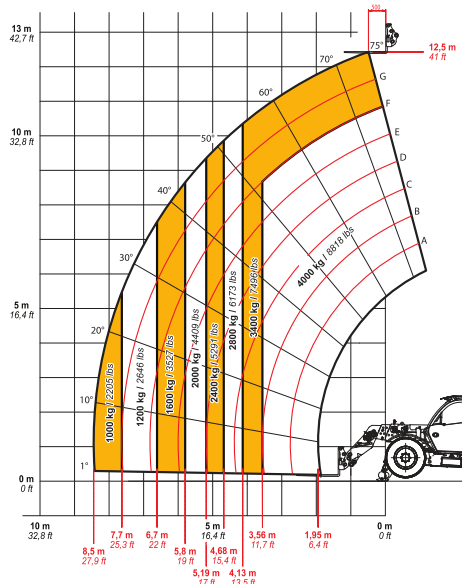

EN1459

40.13